

ZERMA

THE HOME OF SIZE REDUCTION

Shredders // Granulators // Pulverizers // Attachments

ZBS // ZIS // ZSS // ZRS // ZTS/ZTTS // ZWS // **ZXS**

ZXS HEAVY DUTY SHREDDER



The shredders use concave ground square knives, producing high quality output. The cutters can be turned after a side is worn out.

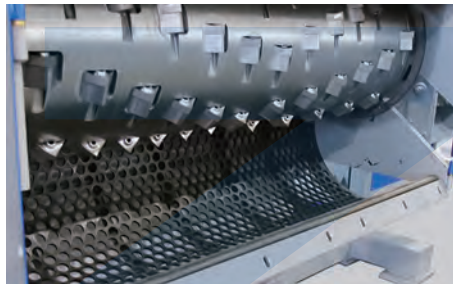

All ZERMA shredders are equipped with a large diameter flat rotor. The knives are fixed in special knife holders fitted in machined pockets. Optional weld on hard facing is available for abrasive applications.



The ZXS shredders feature a high powered twin speed hydraulic system. This system ensures maximum pressure when feeding material into the rotor and high speeds on the backstroke.

GENERAL DESCRIPTION

The ZXS shredders are single shaft shredders with a powerful two speed swing ram design eliminating the risk of blocking and wearing out of internal guide rails. The machine is very versatile and can be used for shredding of all kinds of input materials and is well suited for different industries. The 750 mm diameter rotors ranging from 1500 to 3000 mm width are driven by two oversized gearboxes. The low speed of 45 rpm guarantees a high torque and smooth operation. The hydraulic power pack is well integrated into the machine housing to save space and protect it from damage but still easy to access or remove for maintenance. The proven E rotor, knife holder and knife designs are taken to new dimensions to conquer the most demanding applications and challenges. The machines can be tailored to various applications with advanced controls and hydraulics, hard facing and other wear options.

APPLICATIONS

The ZXS shredders have been designed for the most demanding and high throughput applications in recycling industries. The input materials can be all types of plastics, wood, paper, cardboard, e-waste, post consumer waste, rubber, etc. in various shapes and sizes. Typical input materials are: fridges, purges, tires, pallets, bales, drums and barrels, pipes, film etc... The output material size is determined by the installed screen size and, except in some RDF (refuse derived fuels) and wood applications, the output material may need to be processed further to achieve the desired final size. For the recycling of complete truck and tractor tires the ZXS T model is configured with special wear protection and knives.

ADVANTAGES

- **Low speed, high torque gear drive**
- **Powerful two speed hydraulic swing type ram**
- **Heavy Duty design**
- **High throughput rates**
- **Suitable for very large and heavy parts**
- **Large diameter rotor (750 mm)**

ENGLISH

PLASTIC SIZE REDUCTION
RUBBER SIZE REDUCTION
WOOD SIZE REDUCTION
E-WASTE SIZE REDUCTION



ZXS HEAVY DUTY SHREDDER



ZERMA. THE
HOME OF SIZE
REDUCTION



PLASTIC
SIZE
REDUCTION

RUBBER
SIZE
REDUCTION

WOOD
SIZE
REDUCTION

E-WASTE
SIZE
REDUCTION

SPECIFICATIONS

Type ZXS	1500	2000	3000
Rotor diameter (mm)	750	750	750
Rotor width (mm)	1500	2000	3000
Rotor speed (rpm)	46	46	46
Drive capacity (kW)	2 x 75	2 x 90	2 x 132
Rotor knives (pcs)	76	96	136
Stator blades (rows)	1	1	1
Ram feeder drive (kW)	11	11	11
Screen size (mm)	>60	>60	>60
Cutting chamber volume (m ³)	7.75	9.67	13.5
Effective working area (mm)	1500 x 1490	1500 x 1900	1500 x 2600
A (mm)	3580	3580	3580
B (mm)	935	935	1015
C (mm)	3420	3420	3500
D (mm)	2540	2540	2540
E (mm)	1620	2020	2820
F (mm)	3560	4190	5070

DIMENSIONS

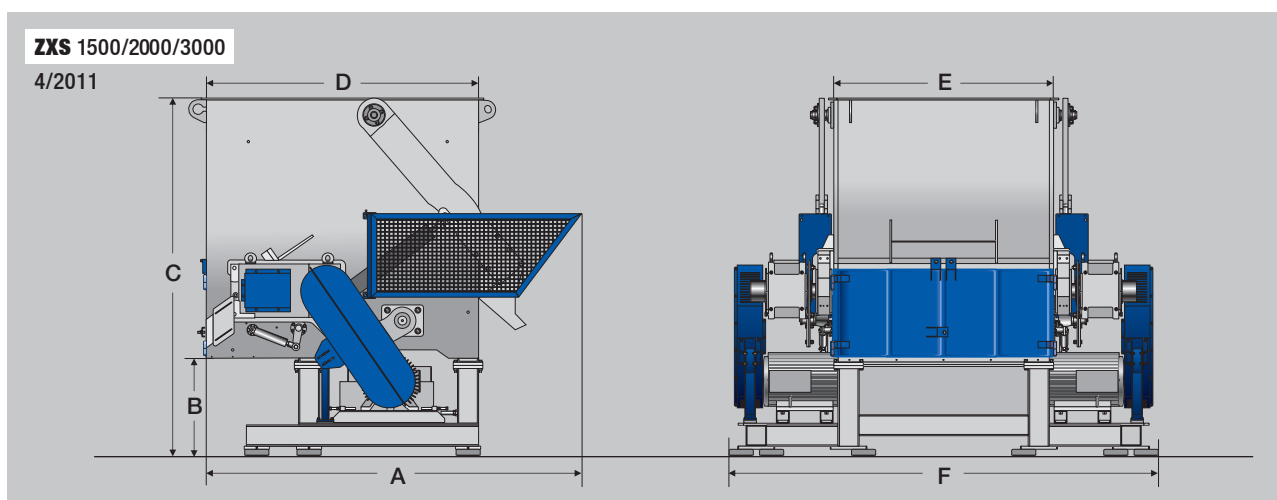

AMIS MASCHINEN-VERTRIEBS GMBH
IM ROHRBUSCH 15 | 74939 ZUZENHAUSEN | GERMANY
PHONE: +49 (0)6226-7890-0 | FAX: +49 (0)6226-7890-222
E-MAIL: INFO@AMIS.DE

ZERMA EUROPE
AMIS MASCHINEN-VERTRIEBS GMBH

WWW.AMIS.DE